

LUXFIT™

LED LIGHT PANEL

Indoor/Dry Location Series

Slim, custom LED light panel for backlighting, edge-lighting and area lighting. Available in custom shapes, sizes, color temperatures—which include static white, tunable white and RGB—and compatible with a wide array of dimmers & controls.

- **Please read all instructions thoroughly before installing the light panel and retain this guide for future reference.**
- **We recommend that light panels be inspected when they are delivered and tested for proper illumination prior to installation and again before any forward facing face materials are applied permanently.**
- **If installing damp location panels, contact the Customer Service team for a damp location installation guidance.**

HANDLING

CARRYING THE PRODUCT

- Stack panels vertically or store them flat. Panels larger than 24" x 36" should be carried vertically by 2 individuals, one on each side, as illustrated here. If the panel is carried horizontally, the acrylic panel will bend and may cause damage to the internal LED electrical components. Refer to the image on the right.
- Do not bend or twist the panels, which can damage the LEDs.
- LEDs will become permanently damaged if the panel bows or warps due to improper handling & storage.
- Be gentle with the wire exit and mindful of wire length so as not to damage it.
- Damage caused by product mishandling will void the warranty.

AVOID MODIFYING THE PRODUCT

- Avoid drilling the product on-site.
- If on-site drilling is necessary, please reach out to the LEDCONN Team for consultation of best practices for your particular application and refer to the "On-Site Drilling" section of this guide for tips.
- Do not cut or modify the product on your own. Modifying a fully assembled light panel may cause damage to the LEDs and panel structure, which will void the warranty.
- Do not remove heat sink. Removing the heat sink will overheat and permanently damage the LEDs.

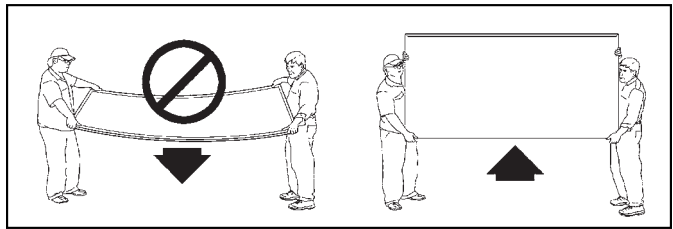

REMOVING THE PROTECTIVE FILM

- LUXFIT light panels are provided with a removable protective film to protect damage to the acrylic surface. Keep this film on the panel until final installation is complete.
- After the product has been fully installed, make sure to fully remove the protective film. Keeping the protective film on will result in a non-uniform appearance.

MOUNTING: BUILT-IN VERTICAL MOUNT

GENERAL RECOMMENDATIONS

- Install the light panel in accordance with project specifications or consult the LEDCONN team.
- Do not expose dry location LED panels to damp or wet environments without specific approval from LEDCONN.
- Secure the LED panels to the assembly with clips, channels, and other non-penetrating fasteners except where specifically permitted, such as any predrilled holes by LEDCONN.
- Consult Architects, General Contractors, or Fabricators for recommendations when field conditions require modifications to approved submittal or mockup.
- When planning to surface mount, make sure you choose a flat, even mounting surface sturdy enough to support panel weight
- Do not over-torque fasteners, which will crack the light panel.
- Drilling holes on-site is not recommended. Request predrilled panels if possible. If holes are needed after panel has been received in hand, call the LEDCONN Customer Success Team for help.

USING ADHESIVES

- Do not apply adhesives on the back of the panel to mount; light panel doesn't support adhesives for mounting.
- Do not apply adhesives on the front of the panel either. Using adhesives on the front of the panel will compromise light quality & evenness and will scratch the surface of the panel.
- Do not glue graphics or laminates directly onto the acrylic surface. This can alter light uniformity and may damage the acrylic.

MOST COMMON OPTIONS

- Mirror clips
- Z clips
- Standoffs
- Predrilled holes

LUXFIT™

LED LIGHT PANEL

Indoor/Dry Location Series

MIRROR CLIPS & Z-CLIPS

As a general guideline, starter clips should be mounted a maximum distance of 6" inward from the corners of the LED panel. Subsequent clips on the horizontal side of the LED panel should be mounted a maximum distance of 18 inches from the previous clip. Clips installed on the vertical side of the LED panels should be spaced a maximum of 30 inches. Please note these spacing measurements are general recommendations that may be adjusted based on clip/stud size, hole size, and application type. Please reach out to a Customer Success team member for any concerns regarding clip installation.

How to Install Mirror & Z-Clips

- 1) Determine the quantity of clips and anchor type required for LED panel installation based on the LED panel weight, overall size, thickness, and mounting surface (concrete, wood, or drywall).
- 2) Starting with the lower edge, mark the location for the starter clips with a maximum of 6" inward from the lower left and lower right corner of the LED panel.
- 3) Use the starter location as reference and mark the locations for the subsequent clips. The subsequent marked locations should have a maximum distance of 18" from the previous clip. Continue marking the clip mounting location(s) until the LED panel is supported every 18".
- 4) Once the clip mounting locations are marked, drill the appropriately sized hole for the wall anchor(s) and fasten the clips to the wall anchors. Do not fasten the clips completely; allow enough room to slide the LED panel between.
- 5) Mark and install the upper clips in the same manner.
- 6) Center the LED panel between the upper and lower mirror clips.
- 7) With the LED panel supported by the upper and lower clips, mark and install the clips to support the vertical sides of the LED panel. The vertical sides of the LED panel should be supported every 30".
- 8) Make sure light panel is completely flat against the surface across the entire panel.
- 9) With the LED panel secured on all 4 sides, fasten all clips until screw is flush with clip. Do not over-tighten the clips to avoid putting stress on the acrylic panel.

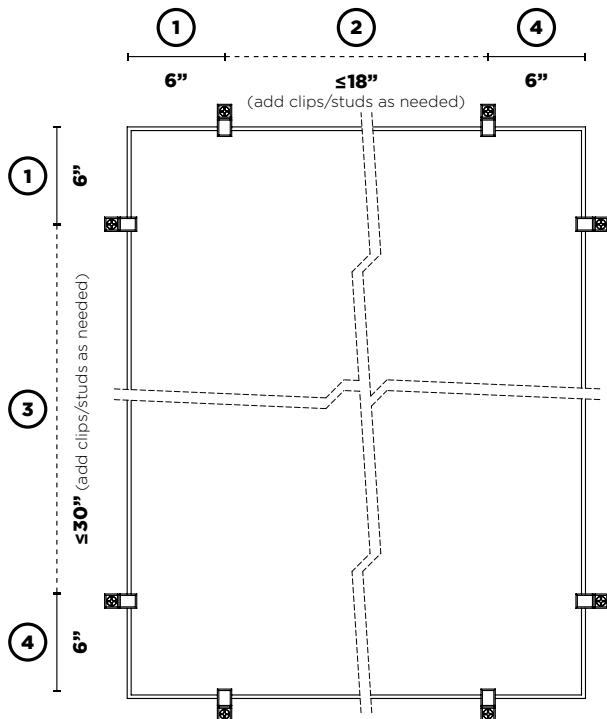
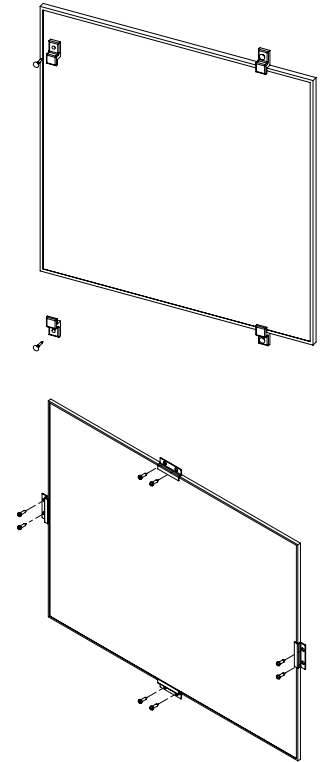

Best Practices for Spacing Mirror Clips, Z-Clips & Standoffs Studs

- 1) Always space the **first clip/stud along any edge 6" from the corner.**
- 2) Space clips/studs out in **horizontal intervals measuring up to 18" or less.** Add additional clips/studs as needed following this horizontal spacing guideline.
- 3) Space clips out in **vertical intervals measuring up to 30" or less.** Add additional clips/studs as needed following this vertical spacing guideline.
- 4) Always space the **last clip/stud along any edge 6" from the corner.**

LUXFIT™

LED LIGHT PANEL

Indoor/Dry Location Series

STAND OFFS

Depending on the type of stand-off used, predrilled holes may need to be requested during LED panel construction to avoid on-site drilling and possible damage to the LED panel. For any standoffs that require screws for installation, please refer to installation instructions provided by your standoff supplier for recommended screw size or type.

How to Install Standard Standoffs

- 1) Determine the ideal stand-off size, length of stud, and wall anchor type required for LED panel installation based on the LED panel weight, overall size, thickness, and mounting surface (concrete, wood, or drywall).
- 2) Use the predrilled holes on the LED panel as a template to mark the points on the installation surface for drilling.
- 3) Install wall anchors using proper installation hardware.
- 4) After the wall anchors are mounted, install the appropriate combination screw, leaving enough external threading to allow the barrel to attach to the exposed end of the combination screw.
- 5) Thread down your selected barrel onto your anchor and tighten.
- 6) Thread the correctly sized stud into the barrel. The stud size is determined by your material thickness and the cap and barrel combination.
- 7) With a plastic washer between the end of the barrel and back of the LED panel, place the LED panel onto the exposed studs and finish off the installation by fastening the caps over the LED panel and thread into the studs.
- 8) Continue applying additional stand offs in this fashion. Make sure to install standoffs 6" from the sides of the panel and allow up to 18" in between stand offs. *For additional spacing guidelines, please follow the "Best Practices for Spacing Mirror Clips, Z-Clips, & Standoff Studs" on page 2.*

How to Install Edge-Grip Standoffs

- 1) Determine the ideal stand-off size, length of stud, and wall anchor type required for LED panel installation based on the LED panel weight, overall size, thickness, and mounting surface (concrete, wood, or drywall).
- 2) Install the edge grips on the LED panels. The LED panel edge needs to sit flush against opening of the edge grip. After aligning the panel inside the edge grips, tighten the set screws inside the edge grips. With all the grips mounted securely on the panel, use the edge grips as a template to mark the point on the installation surface for drilling.
- 3) Install wall anchors using proper installation hardware.
- 4) After the anchors are mounted on the wall, slide the edge grips onto the anchors. Tighten the outside set screw once all grips are seated flush against the anchors. The installation is finished.
- 5) Make sure to install standoffs 6" from the sides of the panel and allow up to 18" in between stand offs. *For additional spacing guidelines, please follow the "Best Practices for Spacing Mirror Clips, Z-Clips, & Standoff Studs" on page 2.*

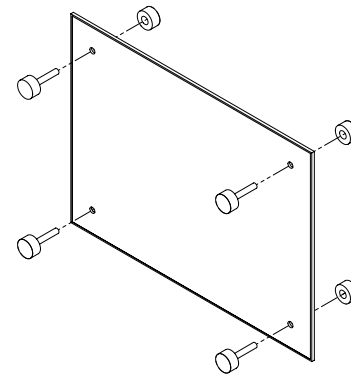

Installing standard standoffs with predrilled holes on the panel.

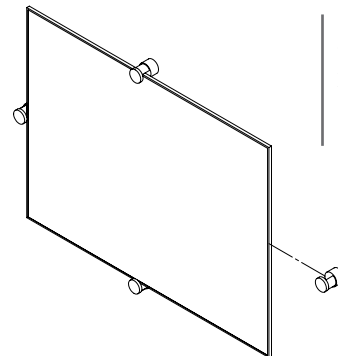

Installing edge-grip standoffs without predrilled holes.

LUXFIT™

LED LIGHT PANEL

Indoor/Dry Location Series

PREDRILLED HOLES

Predrilled hole location and size should be specified during panel construction to avoid on-site drilling and permanent damage to the light panels. Please consult with LEDCONN engineering if holes are needed on-site.

DRILLING HOLES

We highly recommend holes to be specified before production for the highest quality output. On-site drilling, while allowed, can be tricky and may require a high level of skill. **Any on-site drilling is done at the installer's own risk and may void the product warranty.**

General Guidelines for Drilling Holes

- Drilling is allowed only for dry location light panels. Do not drill on damp location treated panels.
- Drilling holes in the **SHADED AREA** can damage the structure of the LED light source.
- With care, holes may be drilled in any other areas of the panel other than the shaded area.
- Depending on the size, location, and number of holes drilled into the panel, light distribution can be affected by: 1) halo effects around the holes; 2) holes drilled too close to the panel edge, which creates dim areas that may compromise light quality.

Drilling Tips

If drilling cannot be avoided, please note the following best practices:

- Drill at slow speeds only! See photo on right.
- Make sure to note the quantity of holes needed to keep the panel flat against the backboard.
- For hand drilling, we recommend perpendicular drilling at standard speeds.
- Monitor drill speed to avoid cracking or melting the acrylic, or creating excess debris that will be lodged between the backer and acrylic.
- Recommended drill speed should be reduced as the size of the drilled hole increases.
- To avoid cracking, holes should not be drilled at a distance from the edge less than 1-1/2 times the diameter of the hole size. For example, a 1/8" diameter hole should be drilled at least 3/16" from the edge.

SHADED AREA

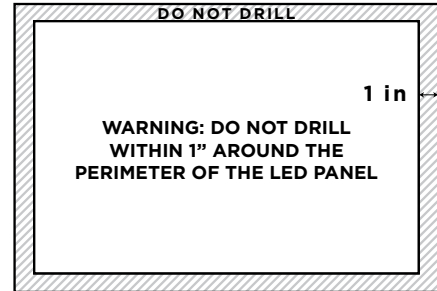

PANEL BACK VIEW



DRILL AT SLOW SPEEDS ONLY.

DO NOT DRILL AT FAST SPEEDS.

CEILING APPLICATIONS ADDITIONAL PRECAUTIONS

To suspend panels, light panels must be placed inside of a structure for hanging. Light panels cannot be hung on their own without a structure holding structural integrity.

OPTIONS

- Aviation cable

RECOMMENDATIONS

- When using a suspension system, depending on the length of the light panel, screws are needed every nine (9) inches.
- To hang panels with an extrusion or channel please refer to the installation guide provided by the extrusion or channel manufacturer for hanging instructions.
- We do not recommend directly suspending the panel without an extrusion.
- Please contact the LEDCONN Customer Success team if you need any help with suspended applications.

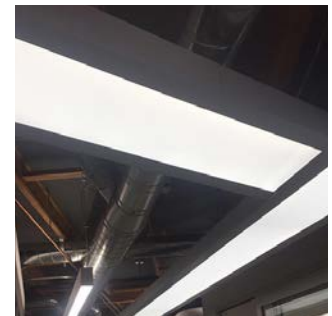

GIVE US ADVANCE NOTICE

Because panels will sag when hung without proper support, **make sure to notify LEDCONN in advance of the intent to suspend the lighting fixture** so that we can prepare the panel and advise specifically for this type of installation.

LUXFIT™

LED LIGHT PANEL

Indoor/Dry Location Series

POWER & WIRING

Dimmers, splitters, extension cords, and power supplies are available for purchase.

ELECTRICAL POWER CONSIDERATIONS

- Use the supplied Class 2 power supply to power the light panel. Product warranty will be forfeited if a power supply not approved by LEDCONN is used.
- LUXFIT light panels are offered with UL & cUL Listed & Recognized Class 2 12V and 24V power supplies. Please check the input voltage for your particular panel and use the power supply that matches the indicated voltage. The total power of the light panel must be lower than the output power of the power supply and dimming controls. Do not use a 12VDC power supply with a 24VDC light panel, or vice-versa.
- Using a power adapter is essential. Never apply direct AC power. Because LUXFIT light panels are low voltage luminaires, using direct AC power can instantly burn the LEDs, permanently damage the product, and void the warranty.

MANAGING VOLTAGE DROP

To avoid voltage drop, wires between light panels and power supplies should be kept as short as possible. For long distances between the power supply and light panel, reach out to the LEDCONN Customer Success and Engineering Teams for wire gauge recommendations.

MANAGING MULTIPLE PANEL CONNECTIONS

- One power supply can power multiple LUXFIT LED light panels as long as the total power consumption of the light panels is lower than the power output of the power supply. Refer to the specification sheet of the selected power supply for suggested load.
- Use the splitters (available in 2-way, 3-way, and 4-way) to connect light panels together in parallel. Contact LEDCONN for custom harnesses.
- Connecting light panels in series is not recommended. Doing so will cause voltage drop that will reduce the light output.

SPLIT CONNECTORS



2-WAY

3-WAY

4-WAY

LEAD WIRING

- LUXFIT light panels are typically provided with a standard 22AWG wire gauge and a 5.5mm x 2.1mm barrel connector; however, lead wire size will vary depending on your application type. If needed, a larger wire gauge will be added to the 22AWG wire gauge to prevent voltage drop.
- LUXFIT light panels are compatible with many power & dimming controls. The output connector can be customized to your application, such as hardwire or special Molex connectors.
- All LUXFIT light panels use a common positive (+) lead wire.

AVAILABLE DIMMING OPTIONS

- 1) Connect the power adapter and the light panel to the dimmer per dimmer instructions.
- 2) Using the dimmer, adjust the light to the desired brightness level.
- 3) For multi-box dimming, you may use a single dimmer for the entire installation as long as the total power consumption is lower than the combined power output of the power supply and max rating of the dimmer.

NOTE: Only use LEDCONN compatible dimmers. The use of any other dimmers can affect light panel performance and will forfeit the warranty. Please consult the LEDCONN engineering team for compatibility concerns.

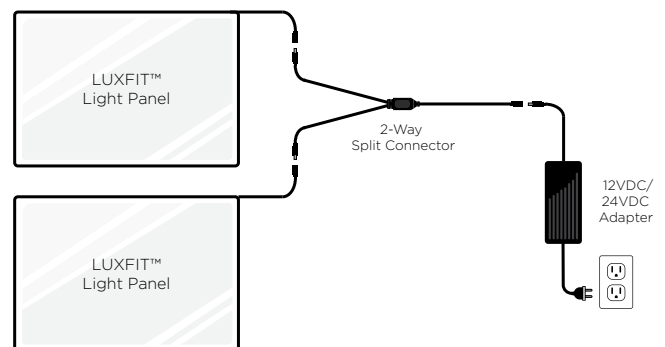
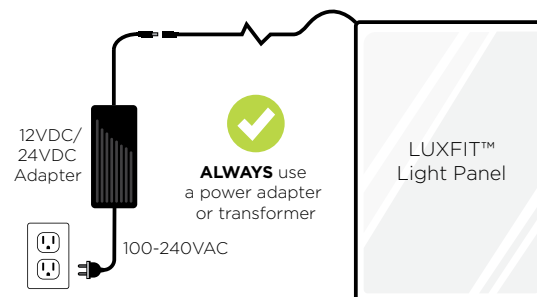
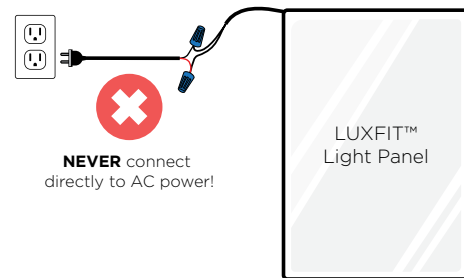

COMPATIBLE DIMMER TYPES



IN-LINE DIMMER

DIMMER WITH REMOTE CONTROL

MAGNETIC LOW VOLTAGE (MLV)

0-10 DIMMING

LUXFIT™

LED LIGHT PANEL

Indoor/Dry Location Series

STORAGE & MAINTENANCE

STORAGE & OPERATING CONDITIONS

- Please store panels in a dry, clean area. Unless otherwise specified, standard dry location light panels are provided with an indoor IP22 Rating.
- Unless light panels have been requested with damp location (IP65) treatment, avoid storing the panels in damp areas.
- To prevent electrical damage and maximize optimal performance, LUXFIT panels should only be used in environments with a relative humidity not exceeding 70% for indoor dry location applications.
- For optimal LED performance, make sure LUXFIT™ LED light panels do not exceed an operating temperature range of -22°F min to +122°F max (-30°C min to +50°C max).
- Operating and ambient temperatures should be properly maintained to avoid overheating the power supplies and controls and to prevent thermal overload of the light panel and power supply. Please check the specifications of all electrical components for recommended operating and ambient temperatures.
- LUXFIT light panels are manufactured with PMMA Acrylic which has a coefficient of thermal expansion of 68 x 10⁻⁶ in/in/°K. This coefficient should be taken into consideration before evaluating operating conditions and mounting methods.

CLEANING TIPS

- To remove dust or dirt, a soft, grit-free, lint-free cloth with naphtha or isopropyl alcohol will usually be sufficient for cleaning. Naphtha or isopropyl alcohol may be used to remove grease and oil deposits (fingerprints) from the panel surface.
- Make sure the cloth surface used for cleaning is always clean. Soiled cloths will only rub additional dirt particles into the panel surface, which can cause additional scratches. Use multiple cloths if needed.

CLEANING PRODUCTS TO AVOID

- Do not use abrasive cleaners or solvent-based window cleaning compounds which will scratch the surface of the acrylic sheet. Such products produce small scratches on the acrylic surface and result in a cloudy look, which is usually permanent and difficult to reverse.
- Do not use solvents or scouring compounds such as Windex®, methyl-alcohol, toluene, acetone, chlorinated solvents, dry-cleaning solutions, lacquer thinners, gasoline, ketones, halogens, etc., which may damage the surface.
- Do not use cleaning products containing ammonia, which will turn the acrylic surface cloudy and eat through the material.
- Do not use any cleaning products that could potentially eat through the acrylic surface.

IMPORTANT SAFETY INSTRUCTIONS

If you feel you do not have adequate wiring experience, please have a qualified licensed electrician install this product for you.

All electrical connections must be in accordance with local codes, ordinances and the National Electric Code. Always confirm that the maximum wattage of the light panel does not exceed the maximum wattage of the connected electrical circuit. If you are unfamiliar with methods for installing electrical wiring, secure the services of a qualified electrician.

- **IMPORTANT** Risk of fire or electric shock. Installation of this product requires a person familiar with the construction and operation of the luminaire's electrical system, installation code, and the electrical hazards involved. If not qualified, do not attempt installation. Contact a qualified electrician.
- **IMPORTANT** To prevent wiring damage or abrasion, do not pinch or damage exposed wiring during installation. Keep away from edges of sheet metal or other sharp objects
- **IMPORTANT** Risk of fire or electric shock. Do not alter, relocate, or remove wiring, power supply, or any other electrical component.
- This luminaire is intended for installation in accordance with the National Electrical Code and local regulations.
- Do not attempt to install or use product until you read and understand the installation instructions and safety labels.
- Verify power is off before installing or un-installing.
- Do not use product if any of the lighting components, power supplies, or controls are damaged.
- The product has no user serviceable parts. Do not attempt to open the product or repair it on-site. If damaged, please notify LEDCONN immediately for servicing.
- Do not exceed the specified voltage and current input (refer to the specification sheet for power limitations).
- Do not hot plug the light engine to an energized power supply. Hot plugging may cause permanent damage to the LEDs.
- LEDCONN's limited 3-year warranty applies only to LEDCONN's LUXFIT LED light panel series.
- Do not make or alter any open holes in an enclosure of wiring or electrical components during installation.
- Please retain these instructions for maintenance reference.
- Our production, packaging and shipping process is governed by a rigorous quality control procedure. All light panels are subjected to a burn in period and are tested before the packaging process to ensure operation at the highest quality. In spite of these rigorous quality control efforts, unforeseen issues may occur during shipping and handling. We recommend that light panels be inspected when they are delivered and tested for proper illumination prior to installation and again before any forward facing face materials are applied permanently.

WARRANTY



**LIMITED
MANUFACTURER
WARRANTY**

These handling and mounting materials and any other communications related to the installation of LUXFIT LED light panels are offered for informational purposes only. Handling and mounting is the installer's responsibility. Under no circumstances is LEDCONN assuming any liability, express or implied, regarding the installation or application of any of its LUXFIT light panels, whether proper or improper. Further, LEDCONN assumes no liability for any costs associated with the installation or re-installation of LUXFIT LED light panels.

The standard warranty for this product is 3 years. Any damage caused by mishandling of the product as outlined in this installation guide will void the warranty. Examples of mishandling include but are not limited to: damage caused by improper drilling techniques; using dimmers or power supplies not recommended by LEDCONN; improper cleaning techniques; improper storage and carrying techniques; improper electrical connections and wiring; and more. Please reference our full warranty statement for more information about warranty coverage.